

37768-MD

500W Reversing Control Module for DC Motor - Continuous Mode

Continuous Mode Control board for DC Motors. Motor starts and keeps running when K1 or K2 Pushbutton Switch signal is applied (Forward or Reverse). **SW1** or **SW2** will stop respective Forward/Reverse motion (useful input for Limit switches).

Inputting opposite Direction Input will change the direction of rotation after ~.3sec.

VOLTAGE: 12VDC

CURRENT 80A max (Surge)

POWER 500Wmax (40A)

K1/K2/SW1/SW2 Inputs: Low level signal (0V or GND)

Operating Temperature:-40 to 80°C Humidity:10%~90%RH

L: 90mm (3-1/2") **W:** 82mm (3-1/4") **H:** 34mm (1-3/8") **WT:** .35

OPERATION

NOTE: "Forward & Reverse" are Relative as to how you connect the motor!

K1/"FORWARD" causes motor to rotate "Forward"

SW1 Signal will Stop "Forward" Rotation Regardless of K1 Signal.

K2/"REVERSE" causes motor to rotate "Reverse"

SW2 Signal will Stop Reverse Rotation Regardless of K2 Signal.

Activation of SW1 or SW2 will Stop rotation Until, either K1 or K2 is activated.

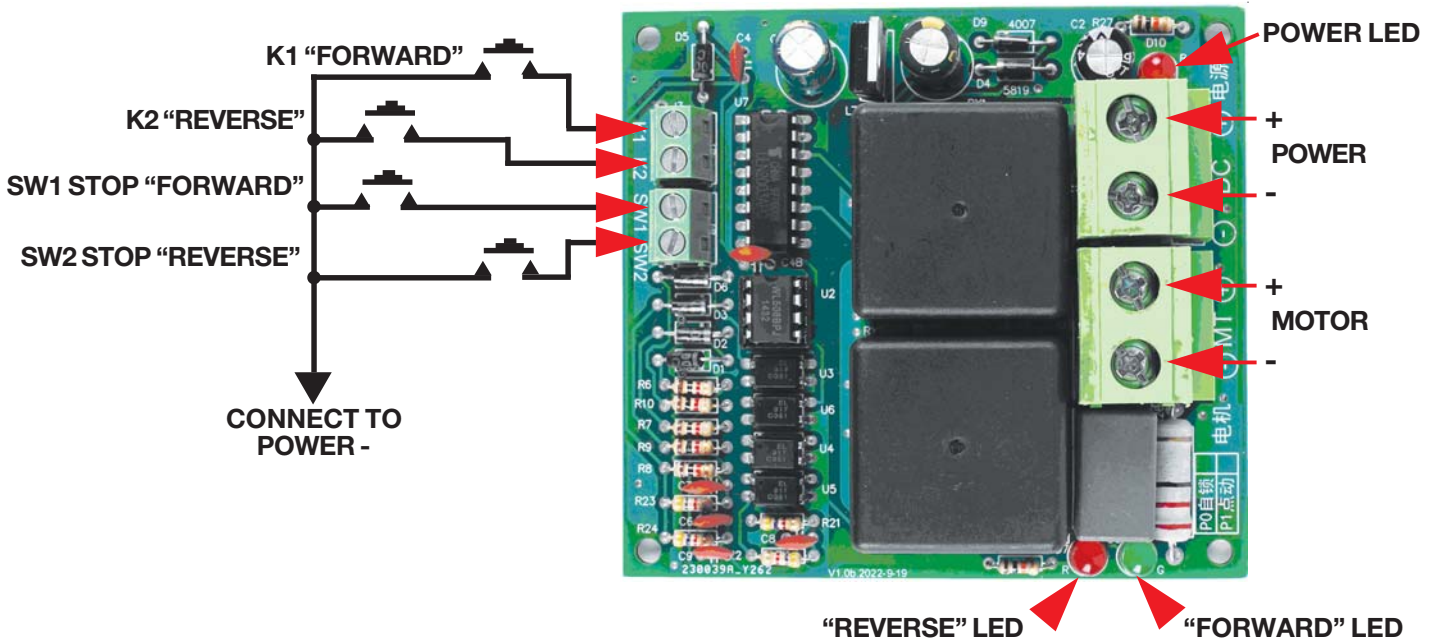

Information including Drawings, Schematics, Links and Code (Software) Supplied or Referenced in this Document is supplied by MPJA inc. as a service to our customers and accuracy or usefulness is not guaranteed nor is it an Endorsement of any particular part, supplier or manufacturer. Use of information and suitability for any application is at users own discretion and user assumes all risk.

Information Subject to Change Without Notice
All rights are retained by the respective Owners/Author(s)



MARLIN P. JONES & ASSOC., INC.

P.O. Box 530400 Lake Park, FL 33403
800-652-6733 FAX 561-844-8764
WWW.MPJA.COM